

Línea Complementarios

Cortadora de cecinas

R-300A

Equipo ideal para comercio y cadenas Food Service



Cuchillas

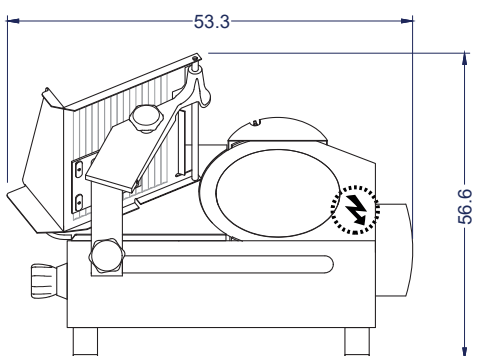

Vista Elevación

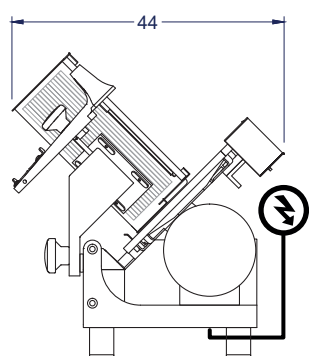

Vista Izquierda

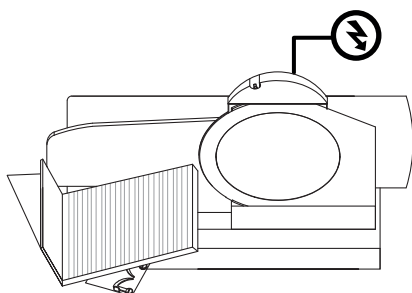

Vista Planta

Unidad: cm

VENTUS[®]



Características

Exclusivo para uso comercial/ Industrial

- Construcción en aluminio anodizado y acero inoxidable.
- Sistema de corte por gravedad.
- Potente sistema de engranes (sin bandas).
- Protector metálico de cuchilla.
- Cuchilla de larga vida fabricado en acero inoxidable de alta resistencia.
- Luz indicadora de encendido y apagado de la máquina.
- Regulador ancho de corte, graduado desde 0 - 25 mm.
- Fácil de limpiar y desmontar.

	Espesor corte	0 - 25 mm		
	Dimensiones equipo	Ancho 53.3 cm	Profundidad 44 cm	Alto 56.5 cm
	Dimensiones disco	Diámetro Ø30 cm		
	Peso	Neto 38 kg	Bruto 51 kg	
	Especificaciones eléctricas	Potencia 0.25 kW	Energía 220V/50Hz	
	Fuerza motor	Potencia 1/3 HP		
	Velocidad	380 rpm		